

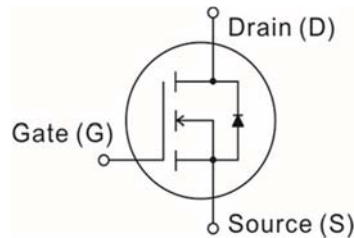

100V N-Channel Power MOSFET

Product Summary

Parameter	Value	Unit
$V_{DS} @ T_{jmax}$	100	V
$R_{DS(on),max} @ V_{GS} = 10\text{ V}$	4.4	mΩ
$I_D @ V_{GS} = 10\text{ V}$	135	A
P_{tot}	250	W

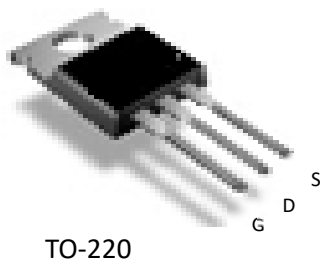

Features

- * Low on-resistance
- * Low gate threshold voltage
- * Excellent FOM

Application

- * Synchronous rectification
- * BMS battery protection
- * DC/AC inverter
- * DC/DC converter

Maximum ratings ($T_A = 25^\circ\text{C}$ unless otherwise noted)				
Parameter		Symbol	Limit	Unit
Drain - source voltage		V_{DS}	100	V
Continuous drain current	$T_C @ 25^\circ\text{C}$	I_D	135	A
	$T_C @ 100^\circ\text{C}$		120	
Pulsed drain current tp limited by T_j max (Note 1)	$T_C @ 25^\circ\text{C}$	I_D pulsed	450	A
Single pulse avalanche energy (Note 2)		E_{AS}	245	mJ
Gate-source voltage		V_{GS}	± 20	V
Power dissipation	$T_C @ 25^\circ\text{C}$	P_{tot}	250	W
Storage temperature range		T_{STG}	- 55 to +175	$^\circ\text{C}$
Operating junction temperature range		T_j	- 55 to +175	$^\circ\text{C}$



100V N-Channel Power MOSFET

Electrical characteristics ($T_A = 25^\circ\text{C}$ unless otherwise specified)						
Parameter	Test Conditions	Symbol	Min.	Typ.	Max.	Units
Off characteristics						
Drain-source breakdown voltage	$V_{GS} = 0\text{V}, I_D = 250\mu\text{A}$	BV_{DSS}	100	---	---	V
Gate-source leakage	$V_{GS} = \pm 20\text{V}, V_{DS}=0\text{V}$	I_{GSS}	---	---	± 100	nA
Zero gate voltage drain current	$V_{DS}= 100\text{V}, V_{GS}= 0\text{V}, T_j=25^\circ\text{C}$	I_{DSS}	---	0.1	1	uA
	$T_j=125^\circ\text{C}$		---	---	100	
On characteristics						
Drain-source on-state resistance	$V_{GS} = 10\text{V}, I_D = 50\text{A}, T_j=25^\circ\text{C}$	$R_{DS(on)}$	---	3.8	4.4	m Ω
	$V_{GS} = 6\text{V}, I_D = 20\text{A}, T_j=25^\circ\text{C}$		---	4.1	---	
Gate-source threshold voltage	$V_{DS} = V_{GS}, I_D = 250\mu\text{A}$	$V_{GS(th)}$	1.5	2.0	2.5	V
Transconductance	$V_{DS} \geq 2 \cdot I_D \cdot R_{DS(on)max}, I_D = 20\text{A}$	g_{fs}	---	82	---	S
Gate resistance	$f = 1\text{MHz}, \text{open drain}$	R_G	---	0.34	---	Ω
Dynamic and switching characteristics						
Gate-source charge	$V_{DD} = 50\text{V}, I_D = 50\text{A}$ $V_{GS} = 0 \text{ to } 10\text{V}$	Q_{gs}	---	15	---	nC
Gate-drain charge		Q_{gd}	---	19	---	
Gate charge total		Q_g	---	72	---	
Turn-on delay time	$V_{DD} = 50\text{V}, I_D = 30\text{A}$ $V_{GS} = 10\text{V}, R_{G,ext} = 3\Omega$	$T_{d(on)}$	---	16	---	ns
Rise time		T_r	---	42	---	
Turn-off delay time		$T_{d(off)}$	---	40	---	
Fall time		T_f	---	16	---	
Input capacitance	$V_{GS} = 0\text{V}, V_{DS} = 50\text{V}, f = 1\text{MHz}$	C_{iss}	---	4000	5200	pF
Output capacitance		C_{oss}	---	650	845	
Reverse transfer capacitance		C_{rss}	---	40	---	
Drain-source diode characteristics and maximum ratings						
Inverse diode forward voltage	$I_S = 50\text{A}, V_{GS} = 0\text{V}$	V_{SD}	---	0.9	1.1	V
Reverse recovery time	$V_R = 50\text{V}, I_F = 40\text{A},$ $di_F / dt = 100\text{A} / \mu\text{s}$	t_{rr}	---	62	---	ns
Reverse recovery charge		Q_{rr}	---	133	---	nC
Peak reverse recovery current		I_{rm}	---	4.3	---	A

Notes:

1. Repetitive rating : pulsed width limited by maximum junction temperature.
2. $V_{DD}=50\text{V}$, starting $T_j=25^\circ\text{C}$.



100V N-Channel Power MOSFET

Thermal characteristics			
Thermal resistance junction-to-ambient	R _{thJA}	62	°C / W
Thermal resistance junction-to-case	R _{thJC}	0.60	

Package Marking and Ordering Information

Type / Ordering Code	Package	Packaging	Related Links
I3GT044N10	TO-220	Tube	see Package outline

Electrical characteristics diagrams

Fig 1: Power dissipation

$P_{tot} = f(T_c)$

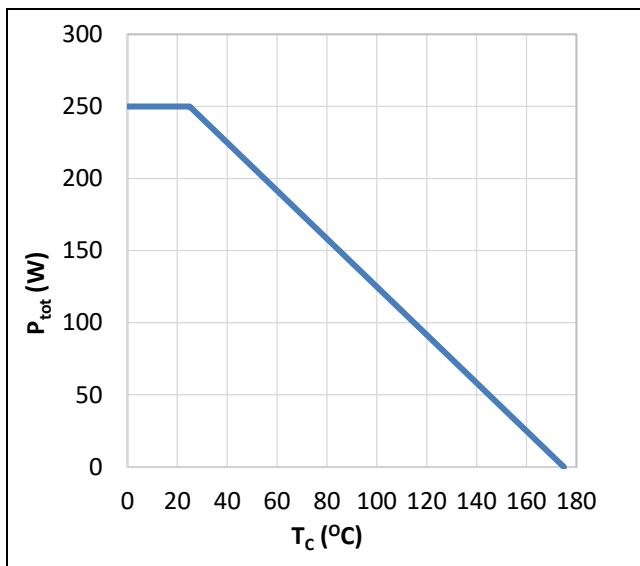
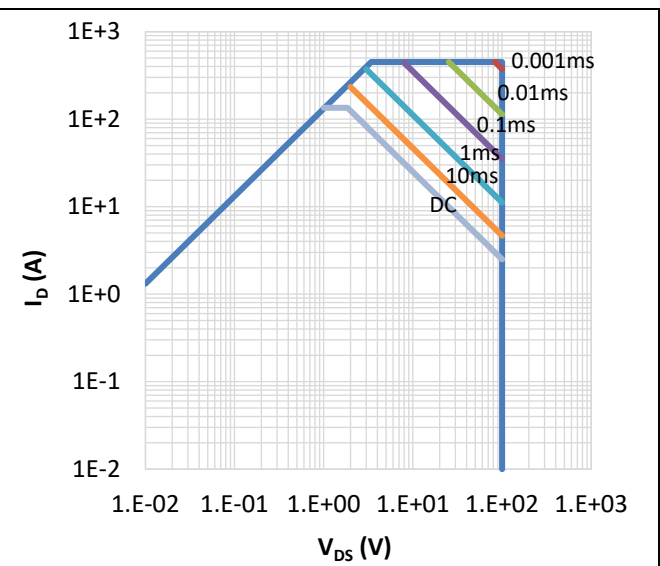

Fig 2: Safe operating area

$I_D = f(V_{DS})$; parameter : D = 0, T_c = 25°C





100V N-Channel Power MOSFET

Electrical characteristics diagrams

Fig 3: Transient thermal impedance

$Z_{thJC} = f(tp)$; parameter : $D = tp / T$

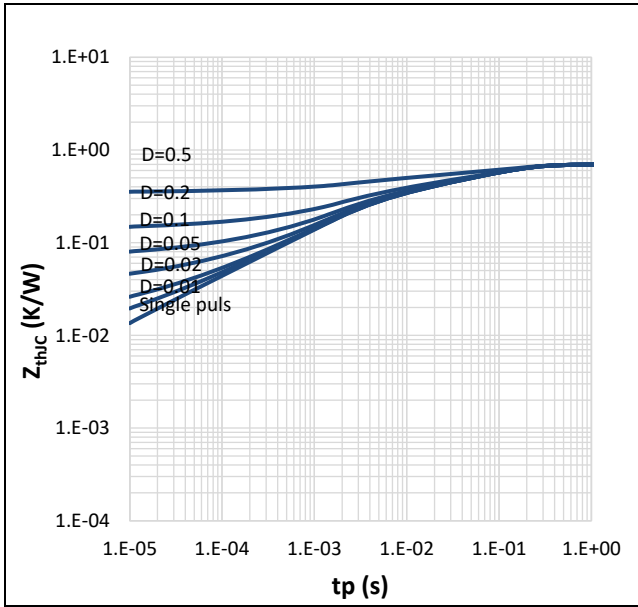

Fig 4: Typ. output characteristics

$I_D = f(V_{DS})$; $T_J = 25^\circ C$; parameter: V_{GS}

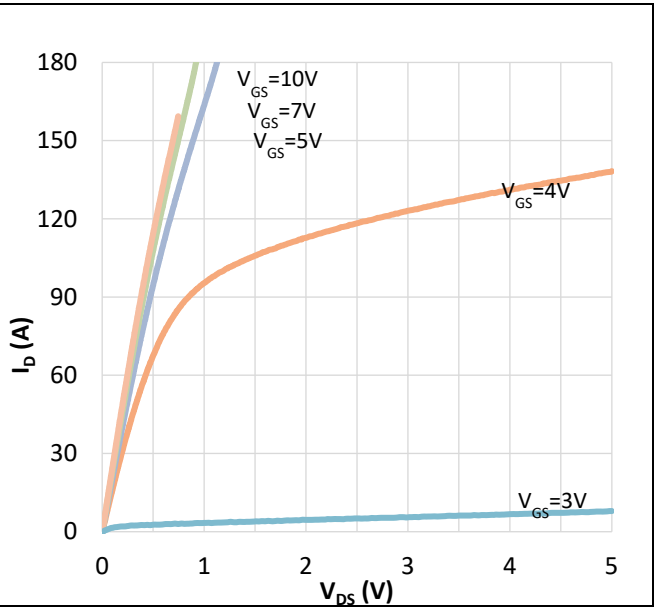

Fig 5: Drain current

$I_D = f(T_C)$; $V_{GS} \geq 10V$

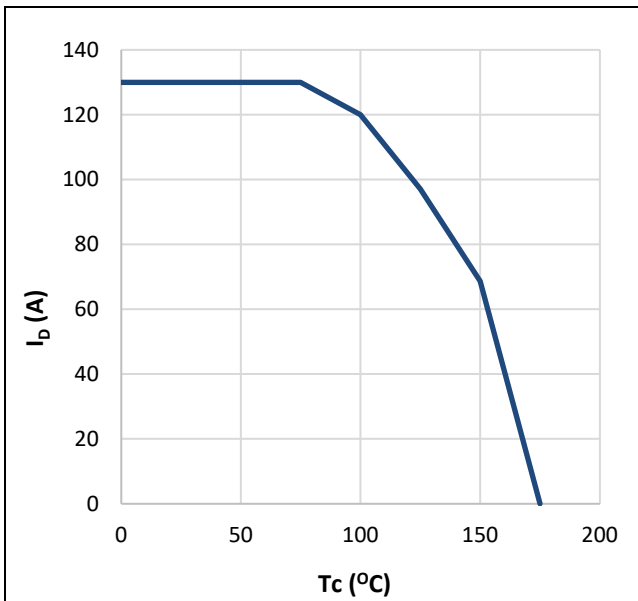
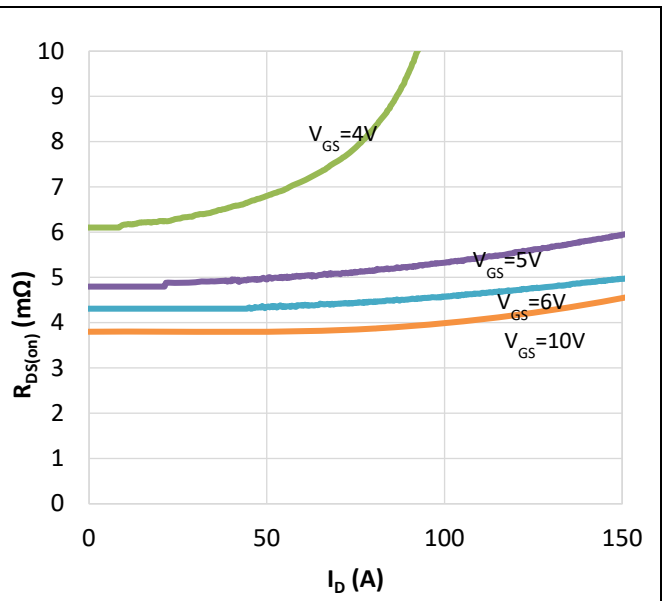

Fig 6: Typ. Drain source on-resistance

$R_{DS(on)} = f(I_D)$; parameter : $tp = 50\mu s, T_J = 25^\circ C, V_{GS}$





100V N-Channel Power MOSFET

Fig 7: Drain-source on-state resistance

$R_{DS(on)} = f(T_j)$; parameter: $I_D = 50A, V_{GS} = 10V$

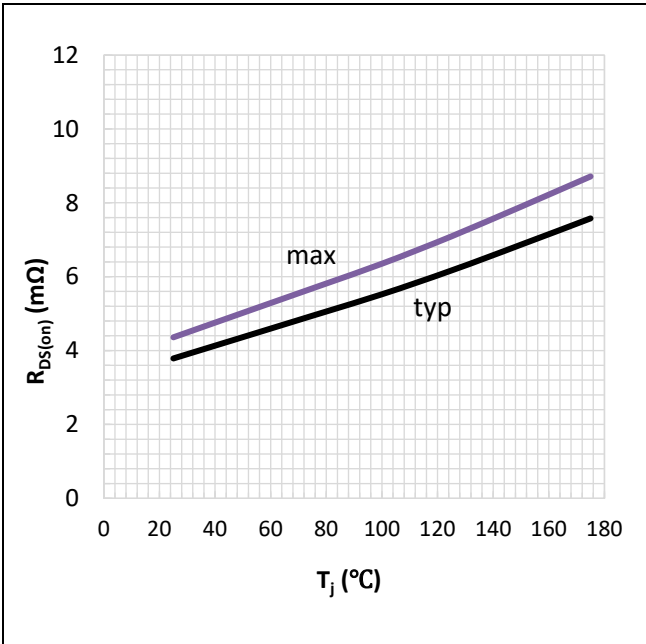

Fig 8: Typ. transfer characteristics

$I_D = f(V_{GS})$; $V_{DS} \geq 2 \times I_D \times R_{DS(on) \text{ max}}$; $T_j = 25^\circ\text{C}$;
parameter: $t_p = 50 \mu\text{s}$

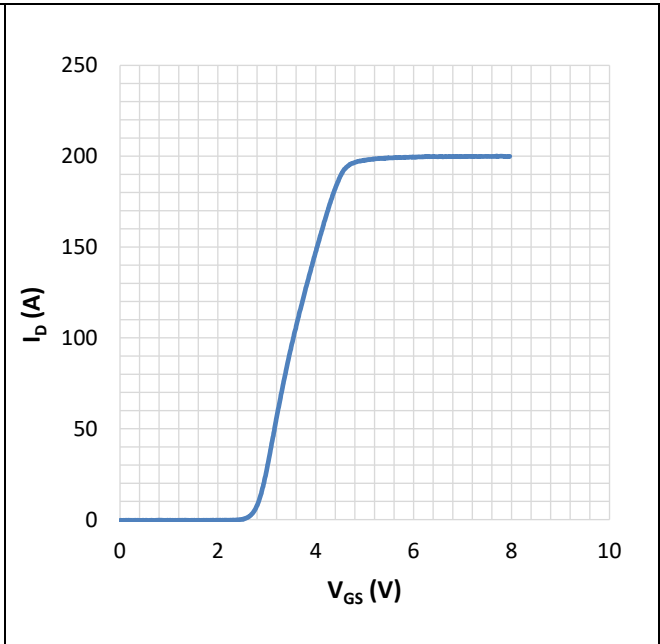

Fig 9: Typ. gate charge

$V_{GS} = f(Q_{GATE})$; $I_D = 50A$ pulsed

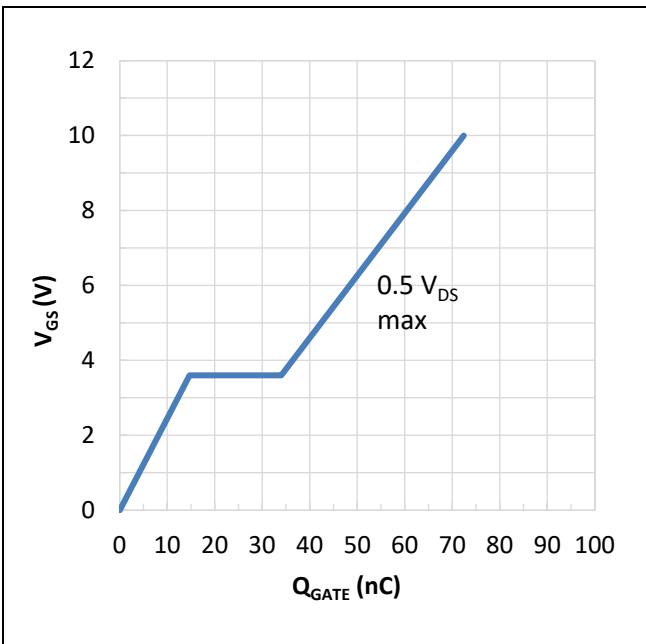
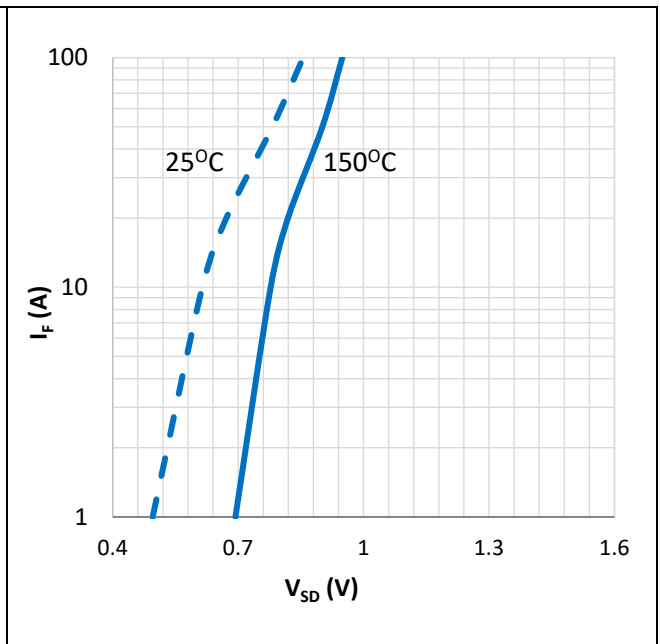

Fig 10: Forward characteristics of body diode

$I_F = f(V_{SD})$; parameter: $T_j, t_p = 20\mu\text{s}$





100V N-Channel Power MOSFET

Fig 11: Drain-source breakdown voltage

$BV_{DSS} = f(T_j)$

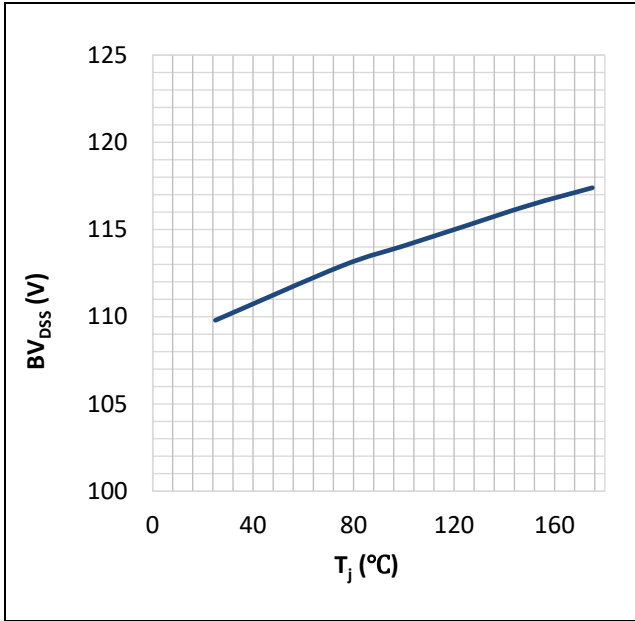

Fig 12: Typ. capacitances

$C = f(V_{DS})$; parameter : $V_{GS} = 0V, f = 1MHz$

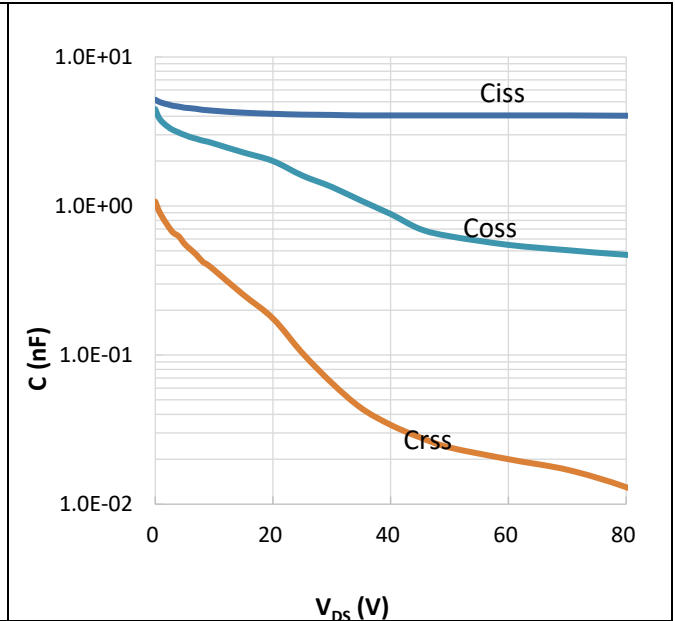
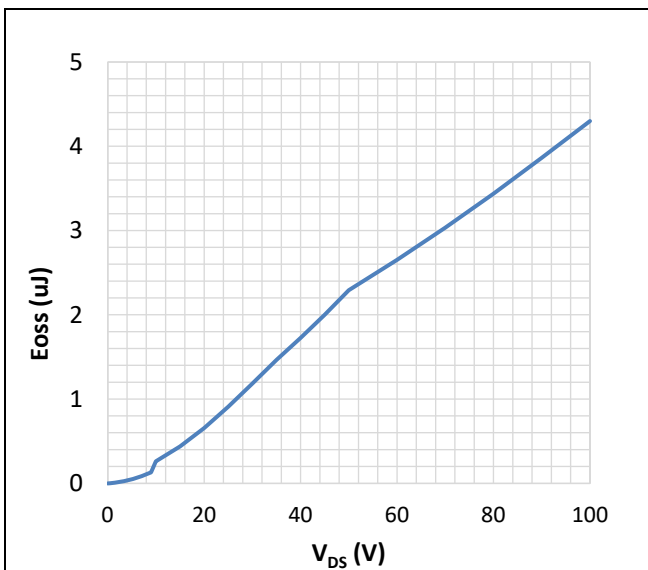

Fig 13: Typ. C_{oss} stored energy

$E_{oss} = f(V_{DS})$





100V N-Channel Power MOSFET

Test Circuit

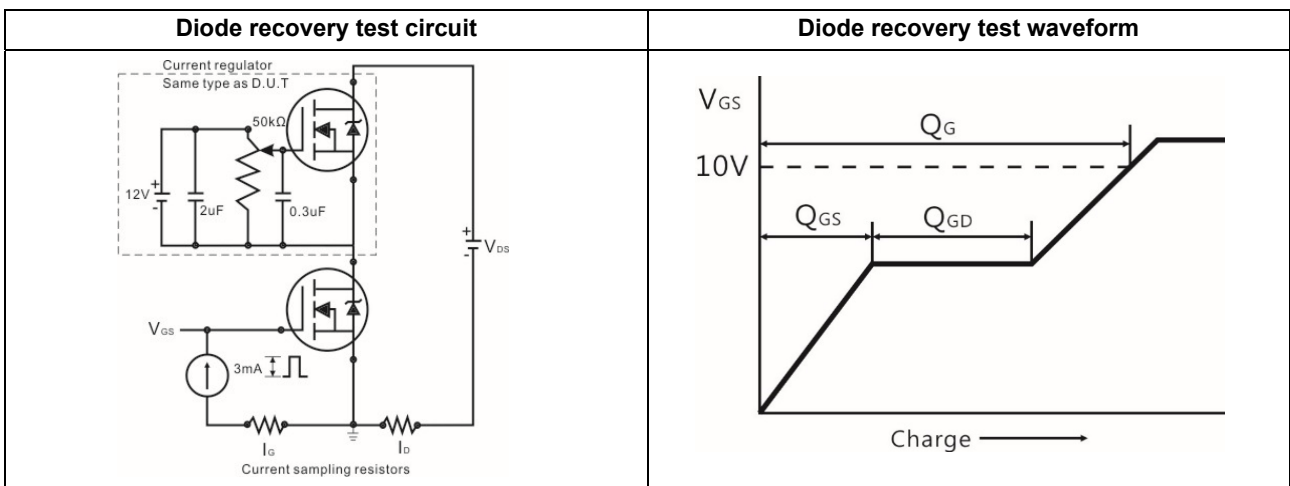
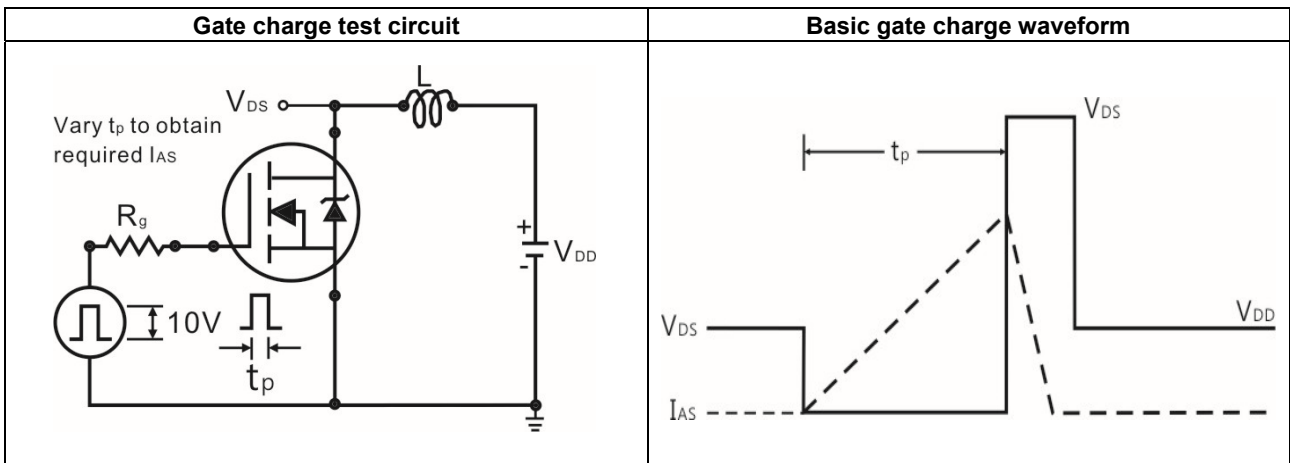
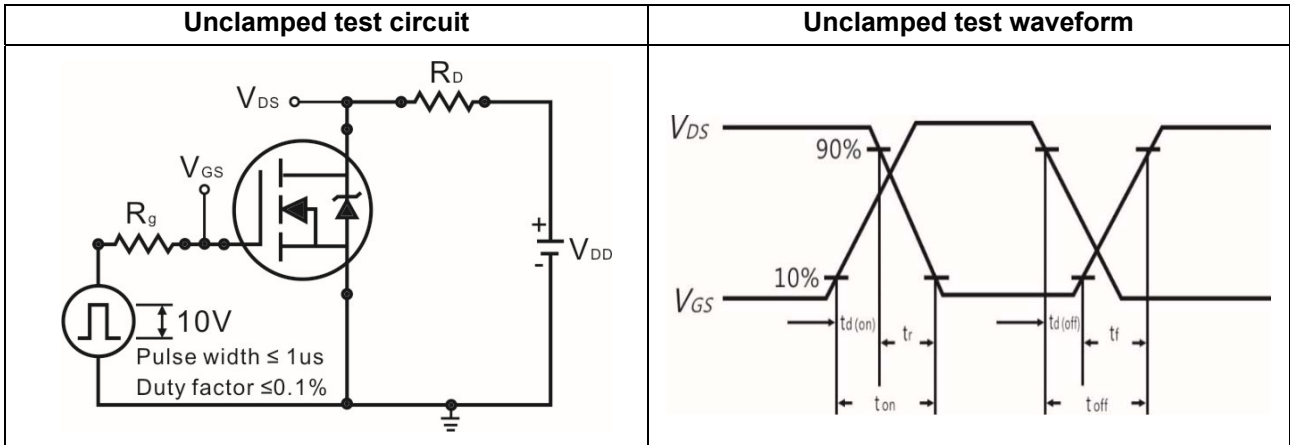



Package outline

TO-220-AB

